

STABL-LEVEL

Installation Instructions For SLM-6A through SLM-192A
Same as SLM M-6A through SLM M-192A

IMPORTANT: SAFETY INSTRUCTIONS

1. **Do not** use Stabl-Level under static loads greater than the indicated maximum. See chart
2. **Do not** fully inflate Stabl-Level unless static weight of equipment to be mounted is placed atop the mount. Read instructions carefully. See note 4 below
3. **WARNING:** Stabl-Level should not be pressurized above 80 psi./ 5.6 bar. If in doubt, the pressure should be checked with a pressure gauge.
4. **If Equipment** is to be removed from mounts, Equipment must be supported so that it has a minimum of 3 3/8 inches of support between equipment and floor before deflating mounts.
5. **Levelness** of the equipment foot to floor: Level should be such that maximum adjustment required not exceed +/- 1/4 inches.

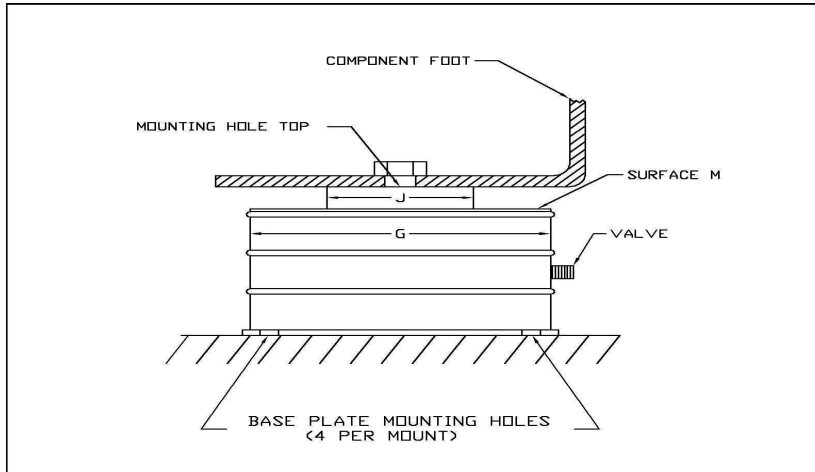

A. TO INSTALL

1. Raise equipment to height greater than 3 1/2 inches (see note # 2) and place Stabl-Level mount between equipment and support base.
2. Insert center bolt and engage threads in mount. Hand tightening is adequate at this point.
3. Install bolts through corner holes provided in mount base plate if mount tie-down is desired.
4. Slowly lower equipment to 3 1/2 inches and inflate Stabl-Level to 45 psi, then gently let equipment rest on Stabl-Level.
5. Tighten all bolts.
6. Sequentially pressurize each mount, increasing the overall height of the mount by 1/8 inch at a time until the overall height of the mounts is 3 1/2 inches.

B. TO LEVEL

1. Bleed or insert air to respectively lower or raise mount height in small increments until desired level is reached.
2. Check each mount for overall height, which should be 3 1/2 inches +/- 1/4 inch. If beyond this range repeat pressurization/bleed process until height tolerance and desired levels are reached.

Mount Part No.	Static Load		Dimensions			
	Min. (lbs)	Max. (lbs)	J"	G"	Mounting Hole Thread x Depth	Hole size for Tie- Down Bolts (in.)
SLM-6A	150	600	2.38	4.99	1/2-13 x .54"	0.29
SLM-12A	300	1200	3.75	6.74	1/2-13 x .55"	0.29
SLM-24A	600	2400	4.75	9.66	5/8-11 x .75"	0.56
SLM-48A	1200	4800	7.50	13.31	5/8-11 x .75"	0.56
SLM-96A	2400	9600	10.75	18.44	1-14 x .88"	0.81
SLM-192A	4800	19200	15.75	24.00	1-14 x .88"	0.81

Notes:

- 1 **Never inflate Stabl-Level with out static resistance.**
- 2 **Where applicable place 3 3/8 support block between equipment and mounting surface. Remove after inflation.**
- 3 **The equipment foot should cover the entire top surface "M" of the mount. If not, a plate of diameter "G" should be placed between the foot and the mount.**
- 4 **Barry controls (or any Hutchinson subsidiary) will not be held liable for any personal injury or damage of any equipment including purchased mounts if proper installation and all warnings are not followed. ie: over-inflation or under-inflation, etc**

1300 South County Farm Drive
P.O. Box 160
Ithaca, MI 48847
Ph: (989) 875-2052
Fx: (989) 875-6565